



# **ALU FOLDER**

Manual folding machine for composite panels

# MANUAL BENDING

## HOW ALU FOLDER WORKS



Bends the returning folds of the composite panels with aluminum skins ( ACM, ACP, MCM ) previously fabricated on a Panel Router, Alu Bender or a vertical panel saw.

Once the panel has been placed in position; the operator simply pushes down on the bar in one single motion. The pressure filled pistons make this a one person operation.





The locking and folding feet are completely adjustable and are made of plastic that will not mark or scratch the surface of the composite panel during the bending process, even when folding of all four sides.

The large and accessible working surface is 100 percent straight, resulting in accurate bends that are completed in just a few seconds.



# THE FINAL PRODUCT

The image displays two metal cassette profiles. The one on the left is a dark blue 'Solid aluminum cassette', and the one on the right is a silver 'ACM cassette'. Both profiles are shown in a perspective view, highlighting their L-shaped structure with various cutouts and mounting points. The silver profile has a slightly different internal structure compared to the blue one.

**ACM  
cassette**

**Solid aluminum  
cassette**



# FEATURES

## ALU FOLDER

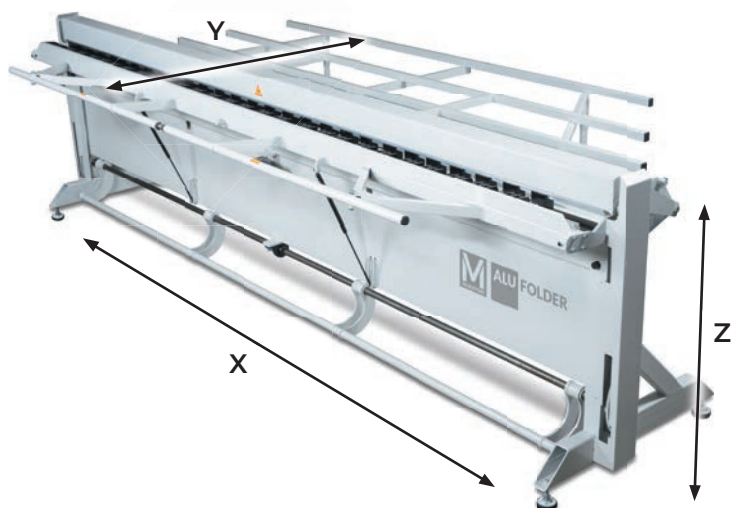

### Dimensions:

#### ALU FOLDER 40

X 4240 mm - 167"

Y 2160 mm - 85"

Z 1150 mm - 45"

#### ALU FOLDER 50

X 5200 mm - 205"

Y 2160 mm - 85"

Z 1150 mm - 45"

## ALU FOLDER 40

Folding width	4000 mm - 157"
Maximum returning fold width*	48 mm - 1" 7/8
Activation	Manual
Approx. weight	kg. 450 - Lb. 992

## ALU FOLDER 50

Folding width	5000 mm - 197"
Maximum returning fold width*	48 mm - 1" 7/8
Activation	Manual
Approx. weight	kg. 550 - Lb. 1212

We reserve the right to make modifications. The illustrated machines may show some units which are not included in the standard version. For photographic reasons some units are without protections. The use of the machine must be made with all protections installed.

\*When folding all four sides on a single panel, the maximum fold width is limited to 48 mm or 1.89 of an inch.

# MAIN SECTORS

## WHERE OUR CUSTOMERS OPERATE



### BUILDING, CONSTRUCTION, ARCHITECTURAL FACADES

The architectural facade or cladding sector comprises the external cladding of a building, which creates its aesthetics and provides protection, thermal and acoustic insulation, and is also sustainable and long lasting.

# PROCESSABLE MATERIALS

## PANELS THAT CAN BE PROCESSED BY ALU FOLDER

### ACM/ACP

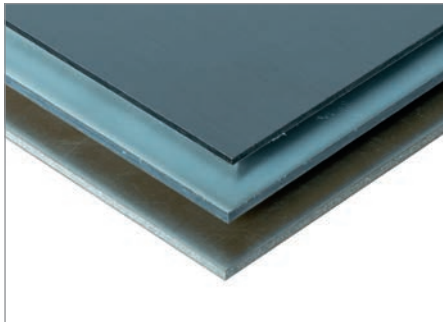

ALUCOBOND®  
LARSON®  
ALPOLIC®  
STACBOND®  
ARCONIC®  
ALUBOND®

ALBOND®  
SIBALUX®  
VITRABOND®  
ALUPANEL®  
NEOBOND®  
.....

### Solid Aluminum

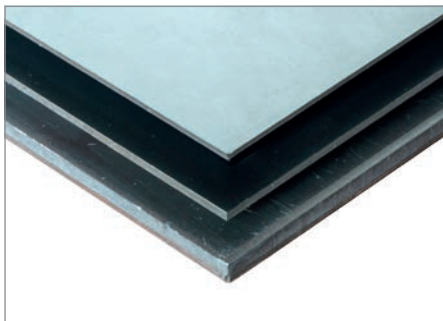

VITRADUAL®  
LUXE COAT®  
ALUCOLUX®  
FUTURAL®  
.....

# MURATORI MACHINES

## ABOUT US

For three generations, the Muratori family has been manufacturing first woodworking machines, and then processing machines for panels made of solid aluminium, ACM, HPL, fibre cement and plastic, which are used in a variety of sectors, including architecture, industry, transport, interior design and visual communication.



**Antonio Muratori** grew up and specialised in the family business where, thanks to his thirty years of experience, he designed and built the technology for handling and processing panels, filing several patents for technological innovations related to Panel Routers and automation systems.

Muratori Machines was thus born from family tradition and know-how and represents the industrial reality in which we design and make innovative technologies, whilst actively listening to the market.

Professionalism, trained eyes and an open mind enable us to meet our customers' needs, while also innovating in the field of automation to respond to their production requirements.

Passionate about work and business, we focus on safety, quality and process efficiency to find solutions that disrupt the status quo and revolutionise traditional design and production paradigms.

## Our Purpose

- We strive for quality for the business and for our team, customers, suppliers and everyone else we work with
- We make active listening and teamwork a priority
- We innovate continuously to improve the efficiency, ergonomics, safety and sustainability of panel processing technology



AVAILABLE IN THE UK THROUGH PCS LTD

UK Registered Office:

**50 Cowick Street, Exeter EX4 1AP**

**+44 (0)3301 75 75 07**

**info@procompositesolutions.com**

[www.procompositesolutions.com](http://www.procompositesolutions.com)

[muratorimachines.com](http://muratorimachines.com)